



# ZHENGZHOU ORIENT POWER CO., LTD

1626, No.9, Sanquan Road, Zhengzhou, Henan, 450000 P.R.China

Tel/Fax:+86 37186097078, sales direct: +86 13673997131

orient@powerinsulator.com <http://www.powerinsulator.com>

## POWER FITTINGS

### Suspension Clamps

Suspension clamps and Strain clamps: are mainly used on overhead power lines and substations. They hang the conductor and ground wire to the insulator strings or hang the ground wire to the tower arms through link fittings.

Suspension clamp: When the suspension clamps are installed on AAC or ACSR, the conductor should be wound by aluminum tapes or preformed armour rods for protecting. There are several types such as XGU trunnion type, XGH envelop type and other types.



### Suspension Clamp (trunnion type)

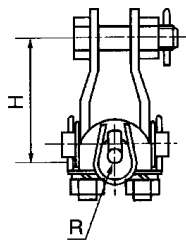
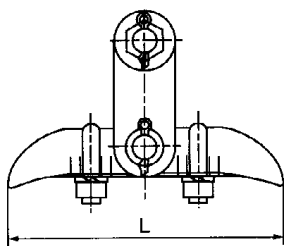

Fig 1

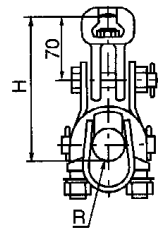

Fig 2

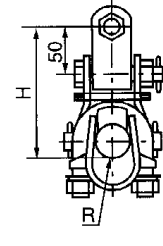

Fig 3



# ZHENGZHOU ORIENT POWER CO., LTD

1626, No.9, Sanquan Road, Zhengzhou, Henan, 450000 P.R.China

Tel/Fax:+86 37186097078, sales direct: +86 13673997131

orient@powerinsulator.com http://www.powerinsulator.com

Cat No.	Conductor Dia.(mm)	Dimensions(mm)			Fig. No.	UTS (KN)	Weight (Kg)
		H	L	R			
XGU-1	5.0-7.0	82	180	4.0	1	40	1.4
XGU-2	7.1-13.0	82	200	7.0		40	1.8
XGU-3	13.1-21.0	102	220	11.0		40	2.0
XGU-4	21.1-26.0	110	250	13.5		40	3.0
XGU-5	23.0-33.0	87	300	17		60	4.7
XGU-6	34.0-45.0	93	300	23		60	5.1
XGU-5A	23.0-33.0	157	300	17	2	60	5.7
XGU-6A	34.0-45.0	163	300	23		60	6.1
XGU-5B	23.0-33.0	137	300	17	3	60	5.4
XGU-6B	34.0-45.0	143	300	23		60	5.8
XGU-7B	45.0-48.7	146	300	26		60	6.4

The body and keeper are made of malleable iron, cotter-pins are made of stainless steel, other parts are made of steel. All ferrous parts are hot-dip galvanized.

## Suspension Clamp (envelope type)

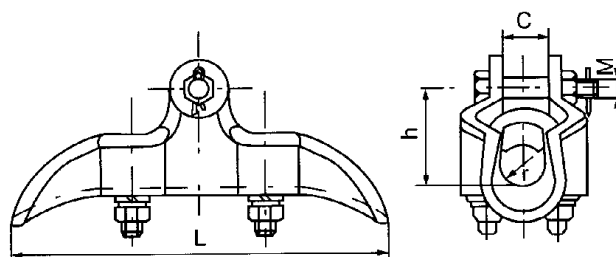

Cat No	Conductor Dia.(mm)	Dimensions(mm)					UTS (KN)	Weight (Kg)
		h	C	M	r	L		
XGT-1	5.0-7.0	54	16	16	6.0	146	71	1.2
XGT-2	6.1-15.3	57	18	16	8.0	171	71	1.5
XGT-3	7.6-17.8	57	18	16	9.0	180	71	1.6
XGT-4	10.2-21.1	60	21	16	11.0	190	80	2.1
XGT-5	12.7-25.4	60	26	16	15.0	203	80	2.6

The body and keeper are made of malleable iron, cotter-pins are made of stainless steel, other parts are made of steel. All ferrous parts are hot-dip galvanized.



# ZHENGZHOU ORIENT POWER CO., LTD

1626, No.9, Sanquan Road, Zhengzhou, Henan, 450000 P.R.China

Tel/Fax:+86 37186097078, sales direct: +86 13673997131

orient@powerinsulator.com http://www.powerinsulator.com

## Suspension Clamp for Twin Jumper Conductors

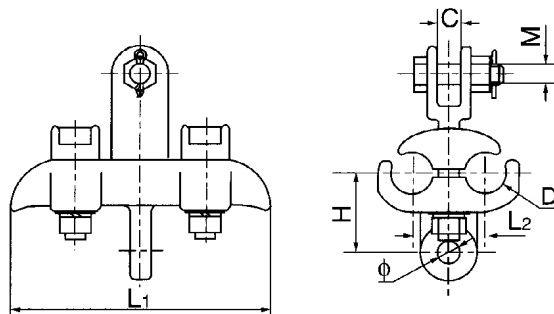

Cat No.	Conductor Dia.(mm)	Dimensions(mm)							UTS (KN)	Weight(Kg)
		Φ	D	L1	L2	M	C	H		
XTS-1	18-24	18	26	200	50	16	19	57	40	4.5
XTS -2	25-31	18	32	200	56	16	19	62	40	5.0
XTS -2A	17-21	18	22	200	50	16	19	57	40	4.5
XTS -2B	21-27	18	28	200	52	16	19	59	40	5.0

The body and keepers are made of malleable iron or cast iron, cotter-pins are made of stainless steel, other parts are made of steel. All ferrous parts are hot-dip galvanized.

## suspension Clamp ( tower top clamp & bracket)

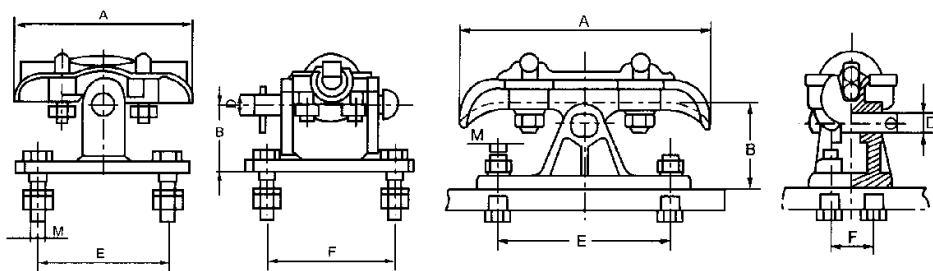

T 型

L 型

Cat No	Conductor Dia.(mm)	Dimensions(mm)						Fig. No.	UTS (KN)	Weight (Kg)
		A	B	D	E	F	M			
XZZ-1T	7.0-12.0	130	70	16	90	90	12	1	70	3.5
XZZ-2T	12.0-18.0	150	70	16	90	90	12	1	70	4.0
XZZ-1L	7.0-16.0	180	70	16	140	34	12	2	70	2.50
XZZ-2L	16.0-26.0	200	70	16	140	34	12	2	70	2.90

Suitable for line post insulator. The body and keeper are made of galvanized malleable iron or Aluminum Alloy, Brackets are made of galvanized or malleable iron.

Cat. No. shall be ended with "T" for malleable iron; ended with "L" for aluminum alloy.



# ZHENGZHOU ORIENT POWER CO., LTD

1626, No.9, Sanquan Road, Zhengzhou, Henan, 450000 P.R.China

Tel/Fax:+86 37186097078, sales direct: +86 13673997131

orient@powerinsulator.com http://www.powerinsulator.com

## Suspension Clamp (envelope type)

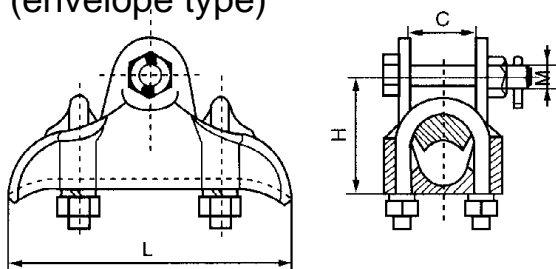

Cat No.	Conductor Dia.(mm)	Dimensions(mm)				UTS (KN)	Weight(Kg)
		L	H	C	M		
XGH-1	5.0-8.5	178	54	17.5	16	50	1.2
XGH-2	7.1-13.0	190	54	18.0	16	50	1.6
XGH-3	11.0-18.5	200	52	22.0	16	50	2.4
XGH-4	17.80-26.0	203	52	27.0	16	50	2.9
XGH-5	23.0-32.0	216	68	33.5	16	60	3.1
XGH-6	25.0-35.0	216	68	36.5	16	60	3.5
XGH-7	27.0-39.0	230	54	40.0	16	70	3.9
XGH-8	28.0-41.2	241	78	43.0	16	70	4.0
XGH-9	31.3-46.2	254	83	48.6	16	70	4.2
XGH-10	35.60-51.80	267	95	54.0	16	70	4.5
XGH-11	44.50-57.20	280	95	58.7	16	70	4.8

The body and keeper are made of aluminum alloy, cotter-pins are made of stainless steel, other parts are made of hot-dip galvanized steel.

## Suspension Clamp (trunion type)

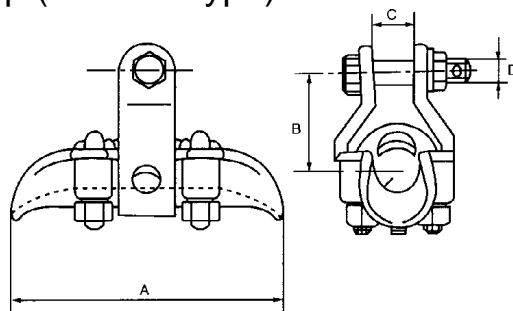

Cat No	Conductor Dia.(mm)	Dimensions(mm)				UTS (KN)	Weight (Kg)
		A	B	C	D		
XGZ-1	11.0-17.0	210	105	24.0	16	70	1.70
XGZ-2	18.0-24.0	270	120	24.0	16	70	2.65
XGZ-3	24.0-28.0	300	145	24.0	16	70	4.40
XGZ-4	28.0-32.0	300	145	24.0	16	70	4.75
XGZ-5	32.0-35.0	300	145	24.0	20	120	4.80
XGZ-6	35.0-42.0	320	160	24.0	20	120	5.50
XGZ-7	40.0-49.0	360	160	24.0	20	120	6.00
XGZ-8	48.0-56.0	360	165	24.0	20	120	6.70

The body and keeper are made of aluminum alloy, cotter-pins are made of stainless steel, other parts are made of hot-dip galvanized steel.



# ZHENGZHOU ORIENT POWER CO., LTD

1626, No.9, Sanquan Road, Zhengzhou, Henan, 450000 P.R.China

Tel/Fax:+86 37186097078, sales direct: +86 13673997131

orient@powerinsulator.com http://www.powerinsulator.com

## Suspension Clamp (carried-up type)

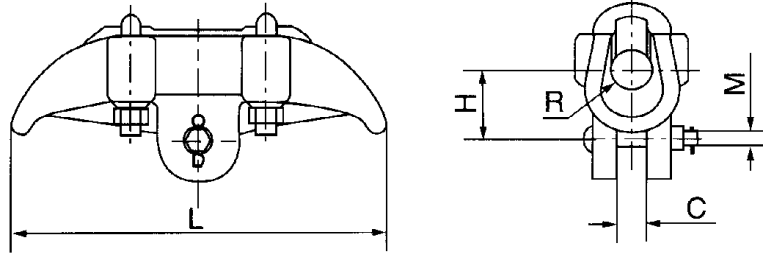

Cat No.	Conductor Dia.(mm)	Dimensions(mm)					Rated Failure Load (KN)	Weight (Kg)
		H	C	M	R	L		
XGF-5K	23.7-27.6	55	24	16	16	300	60	3.0

The body and keeper are made of aluminum alloy, cotter-pins are made of stainless steel, other parts are made of hot-dip galvanized steel.

## Suspension Clamp (hang-down type)

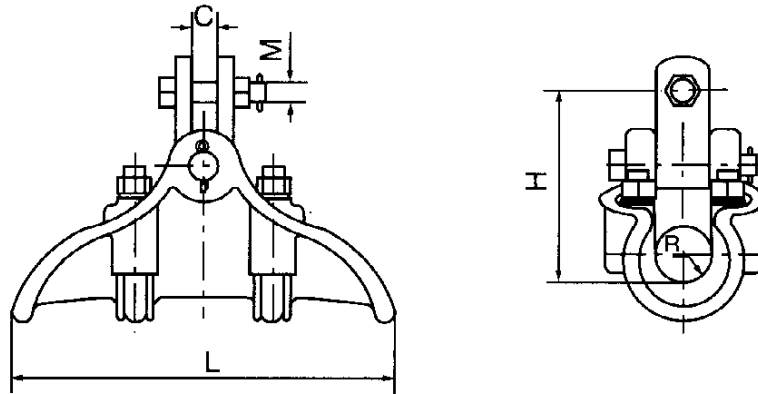

Cat No	Conductor Dia.(mm)	Dimensions(mm)					Rated Failure Load (KN)	Weight (Kg)
		H	C	M	R	L		
XGF-5X	23.7-30.0	135	20	16	16	300	60	3.5
XGF-5X/GH	23.7-30.0	147	20	16	16	300	60	4.8
XGF-6X	36.0-43.0	180	20	18	22	300	90	4.8

The body and keeper are made of aluminum alloy, cotter-pins are made of stainless steel, other parts are made of hot-dip galvanized steel.



# ZHENGZHOU ORIENT POWER CO., LTD

1626, No.9, Sanquan Road, Zhengzhou, Henan, 450000 P.R.China

Tel/Fax:+86 37186097078, sales direct: +86 13673997131

orient@powerinsulator.com http://www.powerinsulator.com

## Suspension Clamp (abrasion-proof type)

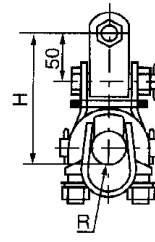
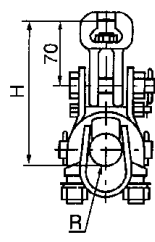
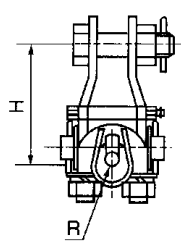
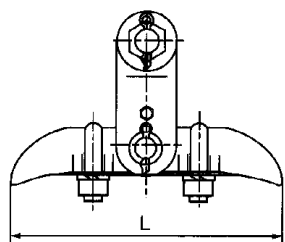

Fig 1

Fig 2

Fig 3

Cat No.	Conductor Dia.(mm)	Dimensions(mm)			Fig. No.	U.T.S (KN)	Weight (Kg)
		H	L	R			
XGU-1F	5.0-7.0	102	180	4.0	1	40	1.4
XGU-2F	7.1-13.0	102	200	7.0		40	1.8
XGU-3F	13.1-21.0	121	220	11.0		40	2.0
XGU-4F	21.1-26.0	132	250	13.5		40	3.0
XGU-5F	23.0-33.0	140	300	17		60	4.7
XGU-6F	34.0-45.0	155	300	23		60	5.1
XGU-5AF	23.0-33.0	210	300	17	2	60	5.7
XGU-6AF	34.0-45.0	220	300	23		60	6.1
XGU-5BF	23.0-33.0	190	300	17	3	60	5.4
XGU-6BF	34.0-45.0	205	300	23		60	5.8
XGU-7BF	45.0-48.7	310	300	26		60	6.4

The body and keeper are made of malleable iron, cotter-pins are made of stainless steel, other parts are made of steel. All ferrous parts are hot-dip galvanized.

## Suspension Clamp for Jumper Conductor

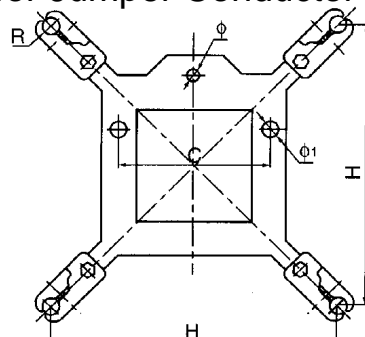

Cat No	Conductor Dia.(mm)	Dimensions(mm)					Weight (Kg)
		H	C	Φ	R	Φ1	
XT4	23.7-27.0	450	240	18	13.5	26	7.0
XT-445/400	13.1-32.0	450	240	18	16.0	26	7.2

The body and keeper are made of aluminum alloy, cotter-pins are made of stainless steel, other parts are made of steel. All ferrous parts are hot-dip galvanized.



## ZHENGZHOU ORIENT POWER CO., LTD

1626, No.9, Sanquan Road, Zhengzhou, Henan, 450000 P.R.China

Tel/Fax:+86 37186097078, sales direct: +86 13673997131

orient@powerinsulator.com http://www.powerinsulator.com

### Top Clamp for Post Insulator

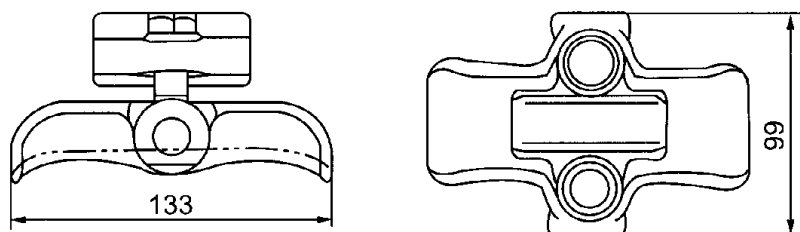

Cat No.	Malleable Iron Made	XZT-1	XZT-2	XZT-3	XZT-4
	Aluminum Alloy Made	XZL-1	XLZ-2	XLZ-3	XLZ-4
Conductor Dia.(mm)	Max.	14.2	21.3	26.9	38.1
	Min.	6.35	8.89	12.7	25.4

Suitable for ANSI class 57-11 to 57-26 horizontal mounting line post insulators. The clamp is made of hot-dip galvanized malleable iron or Aluminum alloy.

### Aluminium Alloy Suspension Clamp (envelope type)

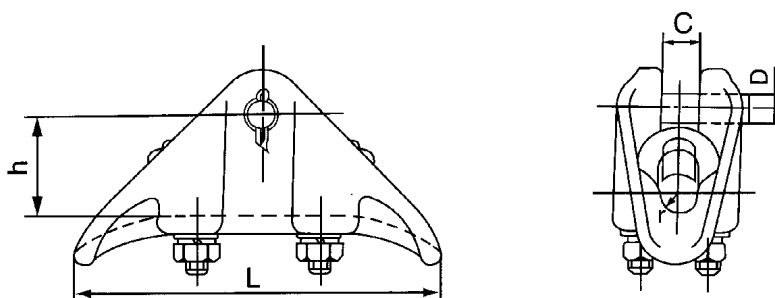

Cat No	Conductor Dia.(mm)	Dimensions(mm)					Ultimate strength (KN)	Weight (Kg)
		h	c	D	r	L		
XGH-3A	12.4-17.0	60	22	16	10	180	39	1.5
XGH-4A	19.0-21.6	74	28	16	12	220	39	2.2
XGH-5A	24.2-28	86.5	35	16	15	256	59	2.8
XGH-8A	49-52	97	56	20	27	300	69	4.5

The body and keeper are made of aluminum alloy. The cotter-pins are made of bronze, other parts are made of hot-dip galvanized steel.